

Ball Balustrading System - B5

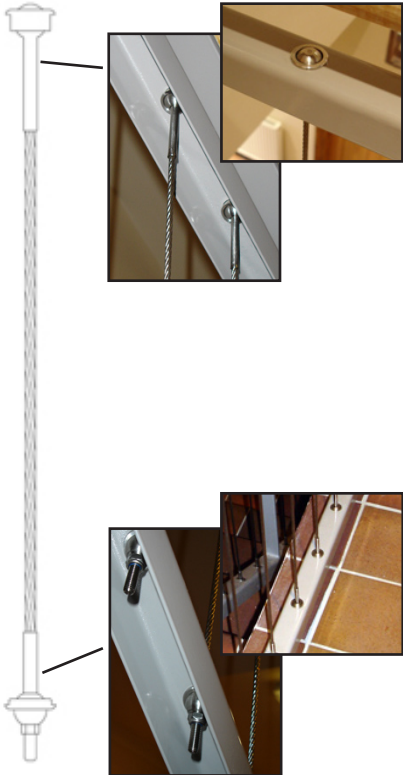

General Applications

The ball system includes a solution for cost effective vertical mounting of wires for balustrade.





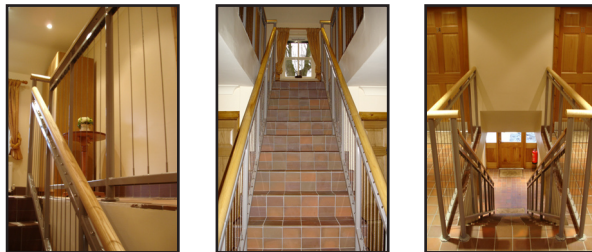

Fitting System B5

The sockets sit in steel plates which must be provided at the top and the bottom of the run. The steel be of a section sufficiently sturdy to resist the loads from tensioning the wires (a 30mm x 30mm x 4mm U-section was used in the example shown in these photographs with vertical support at 1m intervals). If it is desirable the top plate can get support from the handrail itself however the bottom assembly requires access to the back of the fittings. At the top end of the wire a BS04 swage ball sits in a conventional back mounting socket (BCM6).

At the bottom end of the wire a small swage stud (SCM6x4-DS-V) must be attached. The M6 thread of this passes through a ball with a clear-hole (B1/4-C) and is tensioned with an M6 Nylok nut on the back of the stud. This lower assembly sits in a special shallow socket which allows full angle adjustment even with the nut on the back. Sufficient thread is provided to tension the wire but this will be hidden inside the ball so no threads will be visible from above.



LIST OF PARTS REQUIRED

IMAGE	DESCRIPTION AND PART CODE	QTY
	TOP - Back Mounted Socket with "C" Slot (BCM6-C). A Socket is also available without the "C" slot (BCM6)	1
	BOTTOM - Back Mounted Socket with "C" Slot (BCM6-VC). A Socket is also available without the "C" slot (BCM6-V)	1
	Swage Ball Terminal - Use a BS04 for 4mm diameter wire.	1
	1/4" Vertical Ball with clear hole (used in conjunction with SCM6X4-DS-V)	1
	M6 RH Nylok Nut (NYNUTM6R-A4)	1
	Vertical Adjuster Stud M6 for 4mm wire (SCM6X4-DS-V).	1

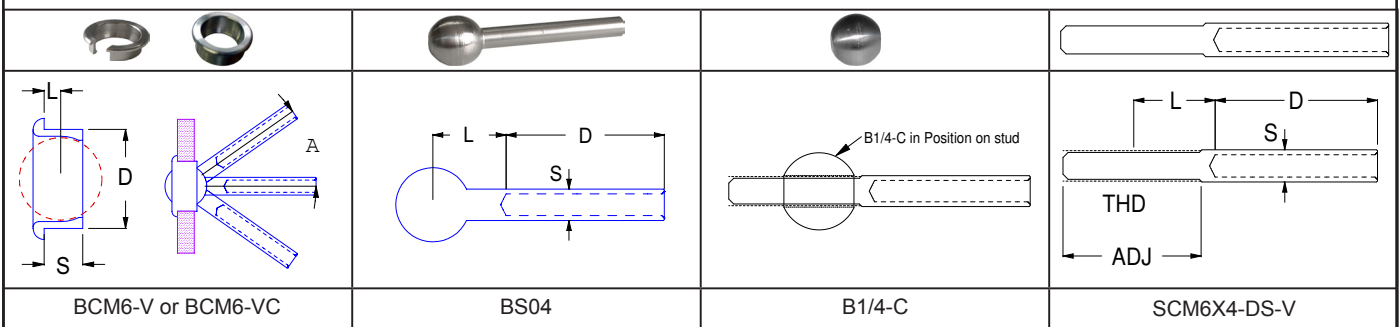

PRODUCT CODE	DESCRIPTION	WIRE DIA.	THREAD TH	BALL DIA	HOLE DIA D	S	L	A	D	ADJ
BCM6-C	TOP Back Mounted Socket with slot			15.9mm	19mm	7.0mm	3mm	40°	19mm	
BCM6-V(C)	BOTTOM Back Mounted Socket with slot			15.9mm	19mm	2.5mm	2.0mm	40°	19mm	
BS04	Swage Ball Terminal for 4mm Wire	4mm		15.9mm		6.3mm	15mm		32mm	
B1/4-C	M6 RH Clear Ball (for use with SCM6X4-DS-V)			15.9mm	The hole through the ball is large enough to pass over an M6 thread					
SCM6X4-DS-V	M6 RH Adjuster for 4mm Wire	4mm	M6			6.3mm	12mm		32mm	+/- 9mm