

# STAINLESS STEEL THREADED EYE

## Threaded Terminals - Eye Studs RH & LH

### Benefits

Electrical upsetting with beneficial grain structure and low stress levels to reduce fatigue.

All threads are precision forged or cut to BS3643 part 1 and 2 and BS1580 part 1 and 2.

Free from structural welds which may reduce the strength and integrity of the product.

All eyes are manufactured from solid bar - no welding involved.

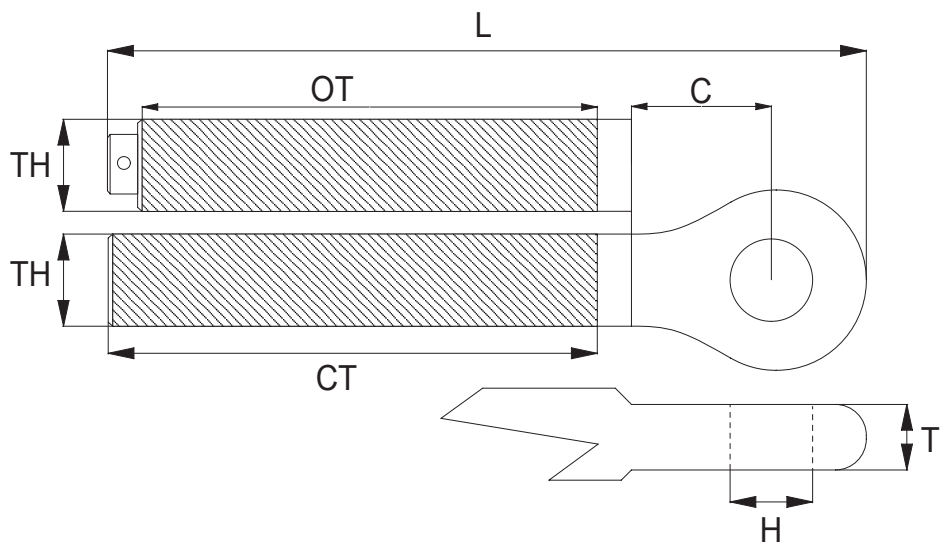

Threaded Terminals - Eye Studs RH & LH

Product Code	Thread	H	C	L	T	CT	OT	Weight
ES#03	1/4" unf	6.35mm	11mm	68mm	5mm	47mm	42mm	16g
ES#04	5/16" unf	8mm	14mm	81mm	6.5mm	54mm	49mm	30g
ES#05	3/8" unf	9.53mm	17mm	99mm	7.8mm	68mm	63mm	54g
ES#06	7/16" unf	11.1mm	20mm	108mm	9.5mm	75mm	68mm	76g
ES#07	1/2" unf	12.7mm	23mm	130mm	11.5mm	90mm	83mm	124g
ES#08	5/8" unf	14.28mm	24mm	148mm	13.5mm	100mm	93mm	218g
ES#10	5/8" unf	16mm	29mm	153mm	15mm	100mm	93mm	236g
ES#12	3/4" unf	19.05mm	34mm	178mm	17.5mm	120mm	111mm	410g
ES#14	7/8" unf	22.2mm	40mm	205mm	21.5mm	140mm	130mm	736g
ES#16	1" unf	25.4mm	46mm	235mm	23.5mm	160mm	150mm	1055g
ES#19	1 1/8" unf	28.58mm	51mm	264mm	27.5mm	180mm	168mm	1490g
ES#22	1 1/4" unf	32mm	58mm	296mm	31mm	200mm	188mm	2031g
ES#26	1 3/8" unf	35mm	63mm	326mm	33.5mm	220mm	208mm	2755g

Replace # with C for Closed Style (CT) or O for Open Style (OT)

All products are produced to a high degree of quality control, using modern lean manufacturing processes, resulting in a reliable and consistent product